

Function



- Applied to 110V, 120V, 220V, 230V, 240V AC low voltage system
- 7+1 digits LCD display (9999999.9 kWh)
- Measure U, I, P, Q, S, PF, F, kWh, kvarh, Multi-tariff energy value
- Record freeze energy for per 15 min/day
- kWh accuracy: 5(6)A Class0.5S, 5(6)A Class1.0
- Support over-voltage timing, under-voltage timing, over-load timing function
- 2 LED indicates pulse (settable for kWh or kvarh)
- LCD display prompt for phase sequence error
- 3 keys for programming 35mm DIN rail installation, standard DIN ED5002
- One RS485 port, MODBUS or DL/T645 protocol (selectable)
- Standard: IEC62053-21/23
- Record historical energy for latest 31 days, latest 12 months

Technical Specification

Rated current	Direct: 5(63)A Or 5(6)A via CT	Connection mode	3P4W
Rated voltage	AC220Vph-N or 120V ph-N (optional)	Pulse output	2 channels (settable for kWh or kvarh)
Frequency	50/60Hz (optional), range: 47 ~ 65Hz	Starting current	0.4%Ib (direct connect), 0.2%Ib (via CT)
Power consumption	< 2W	AC voltage tests	4kV
Power supply	Self supply (note: RS485 won't work, when connect 1 phase) For 220VAC (L-N), range: 184 ~ 276VAC For 120VAC(L-N), range: 96 ~ 144VAC	Accuracy	kWh accuracy: Class 0.5S or Class 1.0
Communication	RS485 serial, MODBUS-RTU or DL/T645 protocol Baud rate: 2400, 4800, 9600 Address: 1~247	Pulse constant	400imp/kWh for 5(63)A 6400imp/kWh for 5(6)A
Environment	Operating temperature: -20 C ~ 55 C Storage temperature: -40 C ~ 70 C Humidity: 5% ~ 95%, non-condensing	Dimension	72*100*65mm (4 module)
		Wire diameters	7mmx7mm (16mm ²)
		Standard (EMC)	Electrostatic discharge immunity test IEC61000-4-2, Level 4 Radiated immunity test IEC61000-4-3, Level 3 Electrical fast transient/burst immunity test IEC61000-4-4, Level 4 Surge immunity test (1, 2/50μs~8/20μs) IEC61000-4-5, Level 4 Conducted emission EN55022, Class B Radiated emission EN55022, Class B

	Parameter	Accuracy	Resolution	Measuring range
Display data, can also be read via MODBUS	Voltage	0.5%	0.01V	For 220VAC (L-N), range:184 ~ 276VAC For 120VAC (L-N), range:96 ~ 144V
	Current	0.5%	0.001A	Direct: 5(63), via CT: 5(6)A
	Active power	0.5%	0.1W	0 ~ 1MW
	Power factor	0.5%	0.001	-1.000 ~ 1.000
	Frequency	0.01	0.01Hz	47 ~ 65Hz
	Active energy	Class 1 for 5(63)A Class 0.5s for 5(6)A	0.1kWh	0 ~ 9999999.9kWh
	Reactive energy	Class 2	0.1kvarh	0 ~ 9999999.9 kvarh
Only can be read via MODBUS	Reactive power	1.0%	0.1var	0 ~ 1Mvar
	Apparent power	0.5%	0.1VA	0 ~ 1MVA

Dimension & Installation

Unit: mm

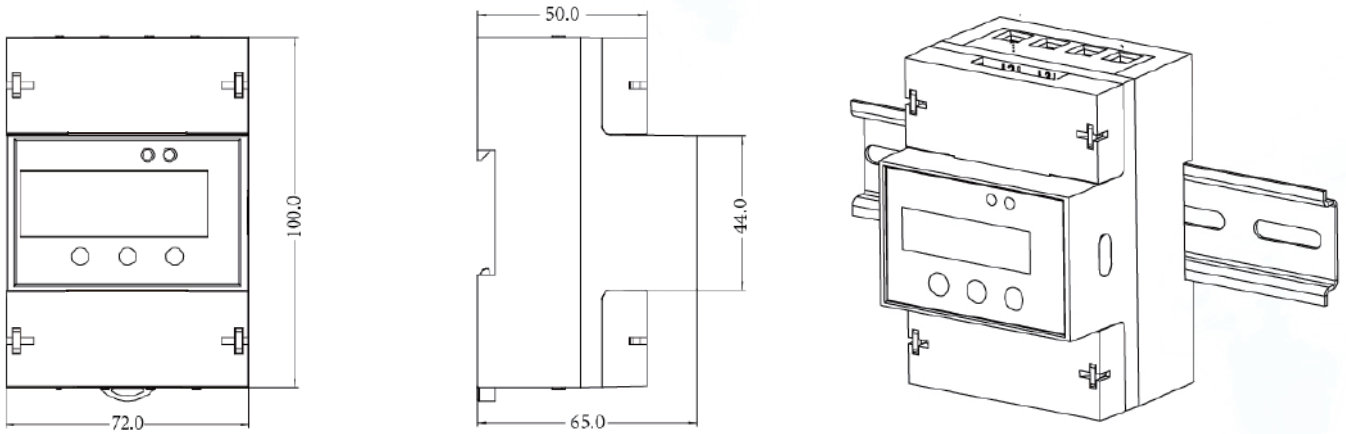

Order Information

DFPM93 ①—②—③ Rated input current (Max.) Rated input voltage Frequency	①	②	③
	63	5	V1
	50	60	V2
	5(63)A direct (class 1.0) 5(6)A via CT (class 0.5s)	220V/380V (Direct) (Suit for 220, 230,240VAC ph-N) 120V/207V (Direct) (Suit for 110,120VAC ph-N)	50Hz 60Hz

For example: DFPM93-63-V1-50 indicates the device providing basic function, accuracy class 1, rated current is 5(63)A, TOU (Multi-tariff) function and rated voltage input is 220/380V, 50Hz.

DFUN (ZHUHAI) CO., LTD.

No.1, keji 4th Road, Chuangxin Hai'an, Tangjia High-tech Zone, Zhuhai, Guangdong, China

+86 756 3639029 519085

info@dfuntech.com www.dfuntech.com

Your Representative